

# Microframe Corporation

Series 200:  
Computer-Controlled Displays



**Operating Manual**

A02X0-7020







## **SERIES 200**

# **INSTALLATION & SPECIFICATION GUIDE**

**ITEM NO: A02X0-7020**  
**REVISION DATE: 01/10**

Microframe Corporation  
604 S. 12th Street  
Broken Arrow, OK 74012

Tel: (918) 258-4839  
Toll Free: 1-800-635-3811  
Website: [www.microframecorp.com](http://www.microframecorp.com)  
E-mail: [support@microframecorp.com](mailto:support@microframecorp.com)

## Limited Warranty Agreement

Your Microframe System is warranted against failure due to defects in workmanship or material for a period of one (1) year from the date of purchase. Microframe Corporation will repair or replace any defective unit. Obvious abuse or mishandling of the unit is NOT covered by this warranty.

## Merchandise Return

If your Unit does not work satisfactorily, please give us a call. We may be able to clear up the problem by phone. If it becomes necessary to return your Unit to the factory, please observe the following.

1. Place Unit in a sturdy box with sufficient packing material.
2. If requested, include the power supply. It is not necessary to return the cable and connectors unless they are the problem.
3. Return the system insured and prepaid since we are not responsible for shipping damages and losses on returned Units.

## Warranty Service

For warranty service, please contact Microframe at: 1-800-635-3811. A technician will gladly assist you.

## Assistance

For any product assistance or maintenance help, contact Microframe by either calling 1-800-635-3811 or emailing us at [support@microframecorp.com](mailto:support@microframecorp.com).

## Safety

Do not install substitute parts or perform any modification to the product without first contacting Microframe.

## Warning

All power transformers, line cords, and electrical equipment should be kept out of the reach of children and away from water. (If you are installing cable in an air plenum area, such as a drop ceiling used for air return, you must use plenum-rated cable. The cable supplied from Microframe is rated CL2 and is approved for installation everywhere indoors except plenum areas.)

## Life Support Policy

**Microframe's products are not authorized for use as components in life support devices or systems without the express written approval of the president of Microframe Corporation.** As used herein:

1. Life support devices or systems are defined as systems which support or sustain life, and whose failure to perform when properly used in accordance with instructions for use provided in the labeling, can be reasonably expected to result in a significant injury to the user or any one depending on the system.
2. A critical component is any component of a life support device or system whose failure to perform can be reasonably expected to cause the failure of the life support device or system, or to affect its safety or effectiveness.

## Disclaimer

We are constantly striving to improve our products. Due to this, specifications are subject to change without notice.

# TABLE OF CONTENTS

|   |           |
|---|-----------|
| <b>MODEL 220 SPECIFICATIONS.....</b>                        | <b>6</b>  |
| <b>MODEL 230 SPECIFICATIONS.....</b>                        | <b>7</b>  |
| <b>MODEL 240 SPECIFICATIONS.....</b>                        | <b>8</b>  |
| <b>MODEL 260 SPECIFICATIONS.....</b>                        | <b>9</b>  |
| <b>MODEL 265 SPECIFICATIONS.....</b>                        | <b>10</b> |
| <b>1 INSTALLATION PROCEDURES.....</b>                       | <b>11</b> |
| 1.1 POWER: 220, 230, 240, & 260.....                        | 11        |
| 1.2 POWER: 265.....   | 11        |
| 1.3 SIGNAL.....   | 11        |
| 1.4 POWER ON.....   | 11        |
| 1.5 SELF-TEST.....  | 11        |
| 1.6 MOUNTING.....   | 11        |
| <b>2 OPERATION.....</b>                                     | <b>12</b> |
| 2.1 DISPLAYING A NUMBER.....                                | 12        |
| 2.2 OPERATING THE DECIMAL.....                              | 12        |
| 2.3 OPERATING THE COLON.....                                | 12        |
| 2.4 SELF-TEST.....  | 12        |
| 2.5 COMMAND STRUCTURE.....                                  | 12        |
| 2.6 DISPLAY ADDRESSING.....                                 | 12        |
| 2.7 OUTPUT CONTROL.....                                     | 13        |
| 2.8 MOMENTARY OUTPUT.....                                   | 13        |
| 2.9 STANDARD ASCII MODE.....                                | 13        |
| 3.0 PROGRAMMING THE DISPLAY.....                            | 13        |
| <b>Programming and Truck Scale Modes.....</b>               | <b>14</b> |
| Truck Scale Modes.....                                      | 14        |
| <b>RS/232 &amp; POWER CONNECTION for: 220.....</b>          | <b>15</b> |
| <b>RS/232 CONNECTION FOR : 230, 240, 260.....</b>           | <b>16</b> |
| <b>RS232 &amp; Power for A Model 265.....</b>               | <b>17</b> |
| <b>RS/485 Connection For Models 230, 240, 260, 265.....</b> | <b>18</b> |
| <b>Single Display 20 mA Current Loop Connections.....</b>   | <b>19</b> |
| <b>Multiple Display 20 mA Current Loop Connections.....</b> | <b>20</b> |
| <b>TROUBLESHOOTING CHART.....</b>                           | <b>21</b> |





# MODEL 230 SPECIFICATIONS

## Remote Display

### Features

The Model 230 Remote Display is designed to operate with any standard RS232, RS485, or 20 mA current loop input to provide Remote Display capabilities for a computer, PLC, or scale display. The Model 230 Display has 5.5-inch tall digits viewable up to 125 feet and is encased in an aluminum extruded cabinet.

### Operation

The computer passes numbers and a carriage return (ASCII 13D ), and the numbers will be displayed on the Model 230. To display a blank screen, pass a carriage return (ASCII 13D). Insert the decimal point in the number string and it will light. Include a colon in the number string to light the colon for that number. Leading zeros will be blanked if the user selectable option is enabled.

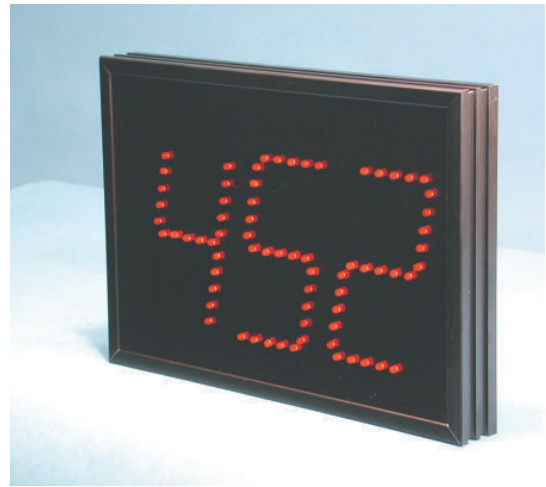

Microframe® Model 230 Display

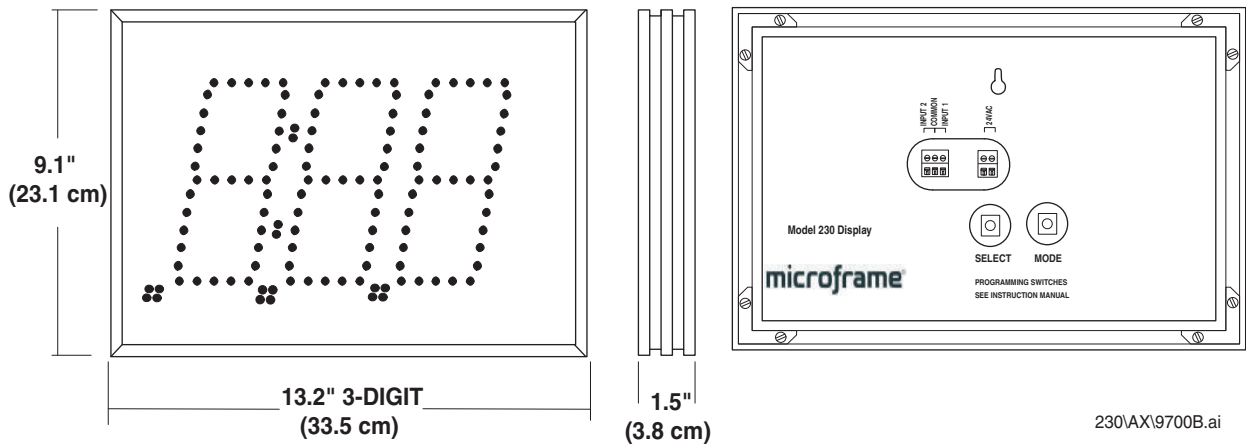

230AX\9700B.ai

### Model 230 Specifications

|                                   |  |
|-----------------------------------|--|
| Protocol.....                     | RS232, RS485, or 20 mA                 |
| Power Input Requirements .....    | 24 VAC or DC @ 1.5 Amps                |
| Baud Rate.....                    | 1200 to 9600 User Programmable         |
| Maximum Number of Addresses ..... | 99 Different Display Addresses         |
| Digit Height .....                | 5.5 Inch (14 cm)                       |
| Character Viewing Distance .....  | 125 Feet in Normal Light               |
| Case .....                        | Aluminum Case with Plexiglas Faceplate |
| Operating Temperature.....        | -20° C to 60° C or -4° F to 140° F     |
| Weight .....                      | 3.0 Pounds (1.4 kg)                    |

**Support and Sales**  
**800-635-3811**

Microframe® Corporation  
 www.microframecorp.com

P.O. Box 1700  
 Broken Arrow, OK 74013



# MODEL 240 SPECIFICATIONS

## Remote Display

### Features

The Model 240 Remote Display is designed to operate with any standard RS232, RS485, or 20 mA current loop input to provide Remote Display capabilities for a computer, PLC, or scale display. The Model 240 Display has 5.5-inch tall digits viewable up to 125 feet and is encased in an aluminum extruded cabinet.

### Operation

The computer passes numbers and a carriage return (ASCII 13D), and then the numbers will be displayed on the Model 240. To display a blank screen, pass a carriage return (ASCII 13D). Insert the decimal point in the number string and it will light. Include a colon in the number string to light the colon for that number. Leading zeros will be blanked if the user selectable option is enabled.



Microframe® Model 240 Display

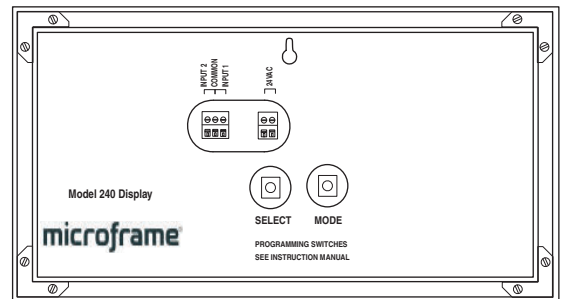
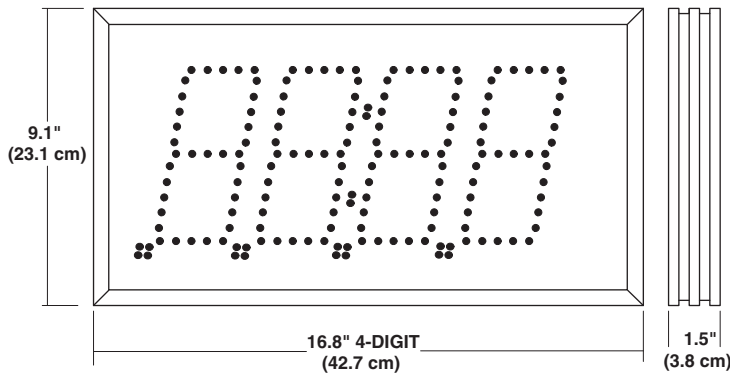

240\AX\9700B.ai

### Model 240 Specifications

|                                   |  |
|-----------------------------------|--|
| Protocol .....                    | RS232, RS485, or 20 mA                 |
| Power Input Requirements .....    | 24 VAC or DC @ 1.5 Amps                |
| Baud Rate.....                    | 1200 to 9600 User Programmable         |
| Maximum Number of Addresses ..... | 99 Different Display Addresses         |
| Digit Height .....                | 5.5 Inch (14 cm)                       |
| Character Viewing Distance .....  | 125 Feet in Normal Light               |
| Case .....                        | Aluminum Case with Plexiglas Faceplate |
| Operating Temperature.....        | -20° C to 60° C or -4° F to 140° F     |
| Weight .....                      | 3.5 Pounds (1.6 kg)                    |

**Support and Sales**  
**800-635-3811**

Microframe® Corporation  
www.microframecorp.com

P.O. Box 1700  
Broken Arrow, OK 74013





# MODEL 260 SPECIFICATIONS

## Remote Display

### Features

The Model 260 Remote Display is designed to operate with any standard RS232, RS485, or 20 mA current loop input to provide Remote Display capabilities for a computer, PLC, or scale display. The Model 260 Display has 5.5-inch tall digits viewable up to 125 feet and is encased in an aluminum extruded cabinet.

### Operation

The computer passes numbers and a carriage return (ASCII 13D), and then the numbers will be displayed on the Model 260. To display a blank screen, pass a carriage return (ASCII 13D). Insert the decimal point in the number string and it will light. Include a colon in the number string to light the colon for that number. Leading zeros will be blanked if the user selectable option is enabled.

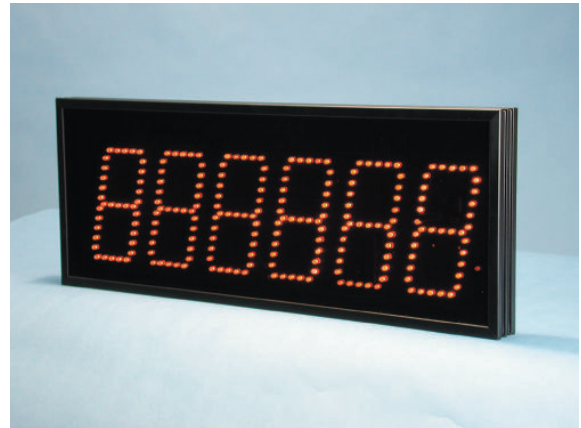

Microframe® Model 260 Display

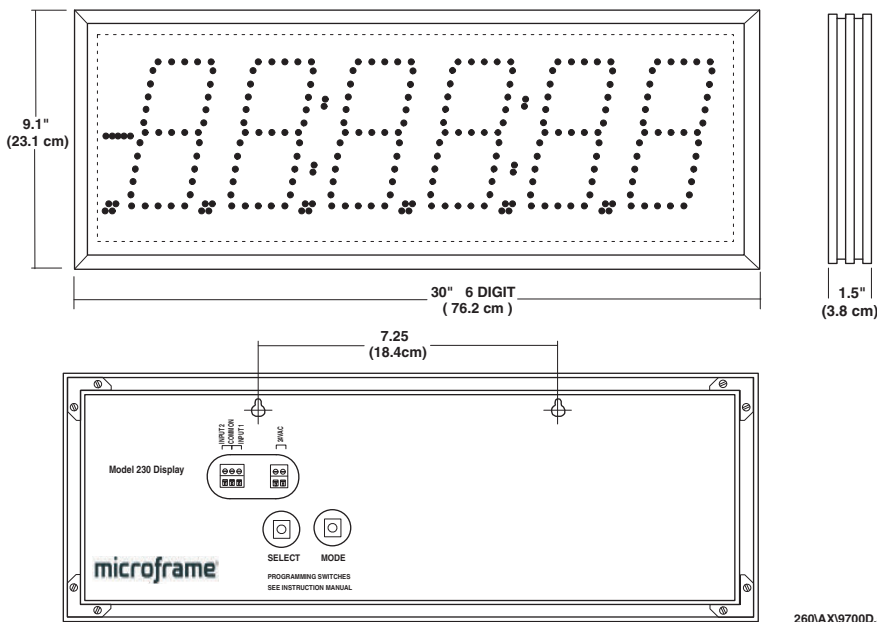

### Model 260 Specifications

|                                   |  |
|-----------------------------------|--|
| Protocol .....                    | RS232, RS485, or 20 mA                 |
| Power Input Requirements .....    | 24 VAC or DC @ .15 Amps                |
| Baud Rate.....                    | 1200 to 9600 User Programmable         |
| Maximum Number of Addresses ..... | 99 Different Display Addresses         |
| Digit Height .....                | 5.5 Inch (14 cm)                       |
| Character Viewing Distance .....  | 125 Feet in Normal Light               |
| Case .....                        | Aluminum Case with Plexiglas Faceplate |
| Operating Temperature.....        | -20° C to 60° C or -4° F to 140° F     |
| Weight .....                      | 5.25 Pounds (2.4 kg)                   |

**Support and Sales**  
**800-635-3811**

Microframe® Corporation  
 www.microframecorp.com

P.O. Box 1700  
 Broken Arrow, OK 74013



# MODEL 265 SPECIFICATIONS

## Features

The Model 265 Ruggedized Display is electrically identical to the Standard Model 260 Display except it comes standard with a 115 AC input. The 12-gauge steel case and 3/8-inch Lexan protects the Display from harsh environments. Like the lighter duty Model 260, it will operate with any standard RS232, RS485, or 20 mA current loop input to provide Remote Display capabilities for a computer, PLC, or scale display. The Model 265 Display has 5.5-inch tall digits viewable up to 125 feet in standard light or 75 feet in bright sunlight.

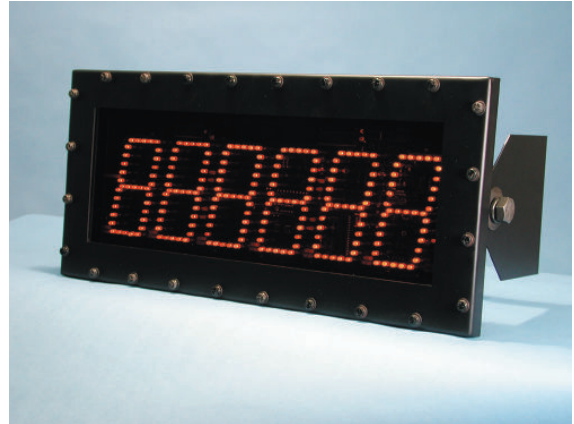

Microframe® Model 265 Ruggedized Display

## Operation

Operation is identical to the Model 260 Display.

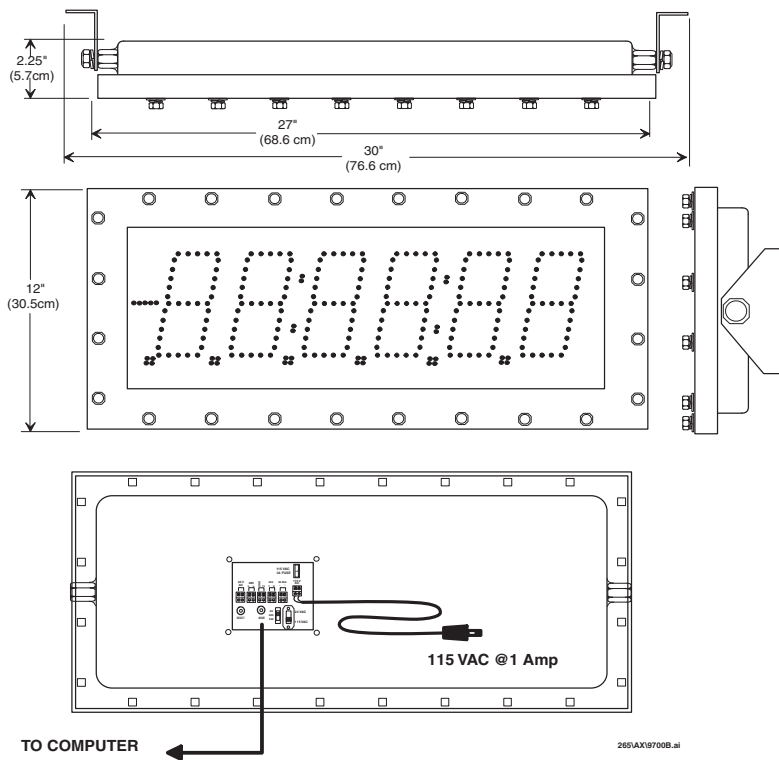

## Model 265 Ruggedized Outdoor Display Specifications

|                                   |   |
|-----------------------------------|---|
| Protocol .....                    | RS232, RS485, or 20 mA                    |
| Power Input Requirements .....    | 24 VAC @ .15 Amps or 115 VAC @ .1 Amp     |
| Baud Rate.....                    | 1200 to 9600 Baud Switch Selectable       |
| Maximum Number of Addresses ..... | 99 Different Display Addresses            |
| Digit Height .....                | 5.5 Inch (14 cm)                          |
| Character Viewing Distance .....  | 125 Feet in Normal Light/75 Feet Daylight |
| Case .....                        | Powder Coated Steel with Lexan Faceplate  |
| Operating Temperature.....        | -20° C to 60° C or -4° F to 140° F        |
| Weight .....                      | 32 Pounds                                 |

**Support and Sales**  
**800-635-3811**

Microframe® Corporation  
www.microframecorp.com

P.O. Box 1700  
Broken Arrow, OK 74013

# 1 INSTALLATION PROCEDURES

## 1.1 POWER: 220, 230, 240, & 260

### *Powering the Display from 24VAC*

The Display ships with a 24VAC power adapter. Connect the wire ends to the board terminals labeled 24VAC. Note: The 20mA current loop input is a signal input and should not be confused with the 24VAC power input.

## 1.2 POWER : 265

### *Powering the Display from 110VAC*

The Display ships with a 110VAC cord installed. Simply plug the cord into an outlet. If the Display does not turn on, verify that the power selector switch is set to 110V.

### *Powering the Display from 24VAC*

To set the Display to run off 24VAC, complete the following: (1) Disconnect the supplied 110VAC power cord; (2) Set the power switch to 24VAC; and (3) Connect the 24VAC source to the terminals labeled 24VAC. Microframe has 24VAC power adapter available as an option.

**Caution:** Connecting 110V to the 24V input will damage the Display.

## 1.3 SIGNAL

Model 220 accepts RS232 as its only input signal.

Models 230-260 accept one of three input sources: RS232, RS485 or 20 mA current loop. A selector switch allows the user to change input settings.

Connections should be as follows:

### RS232

Display Rx to Computer Tx

Display Tx to Computer Rx

Display Ground to Computer Ground

### RS485

A to A, B to B

20 mA Current loop

See diagrams.

Observe that the data input selector switch and baud rate are set appropriately.

## 1.4 POWER ON

The Display power/processor light should flash when the Display is powered.

## 1.5 SELF-TEST

Pressing the select button one time will cause the display to show all eights. Pressing the select button a second time will cause the display to go into a count mode. Pressing the select button a third time will cause the display to show the current software revision. The fourth button press will return the display to normal operation.

## 1.6 MOUNTING

This indoor Display can be wall mounted using the two keyhole cutouts in the back of the Display.

## 2 OPERATION

### 2.0 SERIAL CONNECTION SETTINGS

All serial data should be sent with:  
 8 Data bits, No parity bits, 1 or 2 stop bits.  
 Seven data bits will work if odd or even parity is set.

#### 2.1 DISPLAYING A NUMBER

The Display will show as many numbers as it has digits preceding a carriage return.

(CR) = Carriage Return or ASCII 13d or OD hex.

Alpha characters mixed in with numbers will be ignored (SEE CHART 1 BELOW).

#### 2.2 OPERATING THE DECIMAL

The decimal point can be operated by simply placing the decimal in the number string where you want it to display (SEE CHART 1 BELOW).

#### 2.3 OPERATING THE COLON

You may turn the colon "ON" by passing a colon (:). The colon will remain on for the current number only. (SEE CHART 1 BELOW).

#### 2.4 SELF-TEST

Pressing the select button one time will cause the display to show all eights. Pressing the select button a second time will cause the display to go into a count mode. Pressing the select button a third time will cause the display to show the current software revision. The fourth button press will return the display to normal operation.

#### 2.5 COMMAND STRUCTURE

There are two protocols which can be used to control the display: Legacy mode and Standard CHART 1

ASCII mode. Legacy mode does not support all commands but it acts exactly like older Microframe displays. In this way, code written to drive our older displays will still work. New projects should be written around the

| Descript | On/Off | Command  | Address | End |
|----------|--------|----------|---------|-----|
| HEX      | OE/OF  | 07/08/30 | 30-60   | 03  |

"Standard ASCII" format.

#### Legacy Mode

There are currently three supported commands in "Legacy Mode:" Display Address, Output Control, and Momentary Output. Commands are sent to the Display using a 4-byte data structure, which are defined below:

- Byte #1 On/Off  
 OE = On
- Byte #2 (Command definition)  
 07 = Chime output  
 08 = Momentary Chime on  
 30(hex) = Display enable/disable
- Byte #3  
 30-61(hex) = Display address
- Byte #4  
 03(hex) = Terminating character

#### 2.6 DISPLAY ADDRESSING

To enable Display address number 1, pass the following enable code:

0E 30 31 03 (HEX)

To disable Display address number 1, send the following code:

0F 30 31 03 (HEX)

| Data Sent to Display | Data Shown On Displays |            |            |            |
|----------------------|------------------------|------------|------------|------------|
|                      | <u>220</u>             | <u>230</u> | <u>240</u> | <u>260</u> |
| 1(cr)                | 1                      | 1          | 1          | 1          |
| 123456789(cr)        | 89                     | 789        | 6789       | 456789     |
| :123456(cr)          | 56                     | 4:56       | 34:56      | 12:34:56   |
| a1g2df3(cr)          | 23                     | 123        | 123        | 123        |
| 1.2(cr)              | 1.2                    | 1.2        | 1.2        | 1.2        |
| 1234.56(cr)          | 56                     | 4.56       | 34.56      | 1234.56    |

To enable Display 2 and send "1234," then disable it, send the following hex values:

```
0E 30 32 03
31 32 33 34
0F 30 32 03
```

To set the display address, see the programming instructions.

### 2.7 OUTPUT CONTROL

This command can be used to control the optional "Triac" output. To turn the Triac output on send:

```
0E 07 XX 03
```

To turn off the output send:

```
0F 07 XX 03 X
```

'XX' is the Display address.

### 2.8 MOMENTARY OUTPUT

This command turns the Triac output on for

| Start | Address |    | Command |    | Data |    | End |
|-------|---------|----|---------|----|------|----|-----|
| STX   | A1      | A2 | C1      | C2 | D1   | D2 | ETX |

approximately half a second and then turns off automatically.

```
0E 08 XX 03
```

'XX' is the Display address.

### 2.9 STANDARD ASCII MODE

- STX = (ASCII start byte)
- A1 = Address byte 1(0- 9 ASCII)
- A2 = Address byte 2(0- 9 ASCII)
- C1 = Command Byte 1 (0 -9 ASCII)
- C2 = Command Byte 2 (0-9 ASCII)
- D1 = Data byte 1 (0-9 ASCII)
- D2 = Data byte 2 (0-9 ASCII)
- ETX (ASCII end transmission)

| Commands                    | Data     |
|-----------------------------|----------|
| 01 Display active/inactive  | 01/00    |
| 02 Mirror on/off            | 01/00    |
| 03 Chime on/off/momentary   | 01/00/02 |
| 04 Brightness auto/manual   | 01/00    |
| 05 Brightness value % 1-100 | 00-99    |

#### Example:

To enable display address 72, send it a number and disable it again and send the following:

```
STX 72 01 01 ETX
123456 CR
STX 72 01 00 ETX
```

(Note: Displays power up in the *enabled* state.)

To cause a momentary chime output in display 94, send the following:

```
STX 94 03 02 ETX
```

Brightness 60% on display 15

```
STX 15 05 59 ETX
```

### 3.0 PROGRAMMING THE DISPLAY

Pressing the Mode button one time will get you into the programming mode. The current *mode* is shown by the tens digit and the current

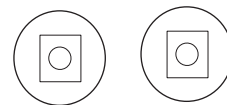
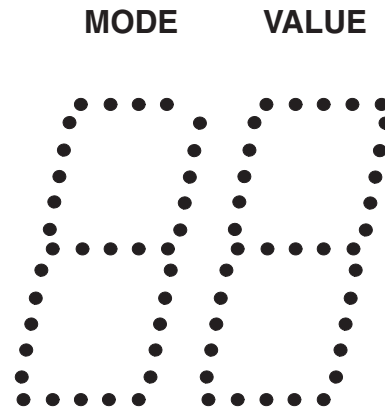

PROGRAMMING SWITCHES

2201PX19700

*value* is shown by the ones digit. Use the Mode button to advance through the mode settings. Use the Select button to change the value of a given mode. When the desired value is set, press the Mode button to advance to the next mode, or press and hold the Mode button to save changes and exit.

#### Area1

- \*Value 0 no alpha characters
- Value 1 Accept alpha characters

#### Area 2

- Value 0 Baud Rate = 1200
- Value 1 Baud Rate = 2400
- Value 2 Baud Rate = 4800
- \*Value 3 Baud Rate = 9600
- Value 4 Baud Rate = 11200
- Value 5 Baud Rate = 38400
- Value 6 Baud Rate = 57600

# Programming and Truck Scale Modes

## Area 3

- \*Value 0 Auto Brightness
- Value 1 2% Brightness
- Value 2 3% " "
- Value 3 5% " "
- Value 4 8% " "
- Value 5 13% " "
- Value 6 22% " "
- Value 7 36% " "
- Value 8 60% " "
- Value 9 100% " "

## Area 4

- \*Value 0 Mirror Mode Off
- Value 1 Mirror Mode On

## Area 5\*\*

- \*Value 0 Zero Suppression/Expansion Off
- Value 1 Show one zero
- Value 2 Show two zeroes
- Value 3 Show three zeroes
- Value 4 Show four zeroes
- Value 5 Show five zeroes
- Value 6 Show six zeroes

## Area 6

- \*Value 0 Colons operate Together
- Value 1 Independent Colons

## Area 7

- Value 0-9 = 10's digit of Address
- \*Factory Default 0

## Area 8

- Value 0-9= 1's Digit of Address
- \*Factory Default 1

## Area 9

- Value 0 Legacy Mode Protocol
- \*Value 1 ASCII Protocol
- Value 2 General Scale
- Value 3 Specific Scale See Mode "A"

## Area A

- \*Value 0 Mettler Toledo
- Value 1 Rice Lake

\* Factory Default

\*\*Modes Legacy and ASCII do simple zero suppression; specified zeroes are ignored.

## Truck Scale Modes

Microframe is committed to making the model 265 display work with as many different scale indicators as possible. To this end, Microframe has developed a General Scale Receive Logic mode which works with most scales. For those few scales which have been found not to work with the "General Scale" mode, we have written specific receive logic. If your indicator cannot be made to work with any of our existing logic, we will write logic specifically for your indicator.

Please note that "Legacy mode" (Area 9 Mode 0) and "Standard ASCII" mode (Area 9 Mode 1) are full command structure protocols. These protocols are generally used in industrial applications where control over display addressing is necessary. These modes can be used with scale indicators but care must be taken to avoid unintentionally sending data in command format. For information about the "Legacy mode" and "Standard ASCII" mode, please see the "Operation" section.

## Area 9 Mode 2 Universal Scale Mode

Example:  
Definition:

|       |    |    |    |    |    |    |    |        |
|-------|----|----|----|----|----|----|----|--------|
| ASCII | -  | 1  | 2  | 3  | 4  | 5  | 6  | CR/ETX |
| HEX   | 2d | 31 | 32 | 33 | 34 | 35 | 36 | 0d/03  |

This is the most universal scale mode. In this mode the start byte does not matter. The Display will show the last six characters preceding a Carriage Return or an "ETX." Alpha characters can be ignored based on the "ignore alpha" option. There are no addressing or special display commands in this mode. Negative signs will be placed where they are received in the string.

## Area 9 Mode 3 Specific Scale Mode

With area 9 set to a value of 3 the protocol is defined by the choice in area "A."

## Area A Mode 0 Mettler Toledo / Lynx / Panther Plus

|     |     |     |     |          |        |    |
|-----|-----|-----|-----|----------|--------|----|
| STX | SWA | SWB | SWC | 6 Weight | 6 Tare | CR |
|-----|-----|-----|-----|----------|--------|----|

This mode differs from standard mode by looking for the weight 6 bytes before the carriage return and for the negative sign designation in byte 1 of SWB.

## Area A Mode 1 Rice Lake

|     |   |          |   |     |   |    |
|-----|---|----------|---|-----|---|----|
| STX | P | 7 WEIGHT | U | G/N | S | CR |
|-----|---|----------|---|-----|---|----|

This mode differs from General Scale Mode by looking for the negative sign in the fixed location "P" shown above. P = polarity, " " = +, "-" = -.

### NOTE:

- All serial data should be sent with:
- 8 Data bits
- No parity bits
- 1 or 2 stop bits.

# RS/232 & POWER CONNECTION for: 220

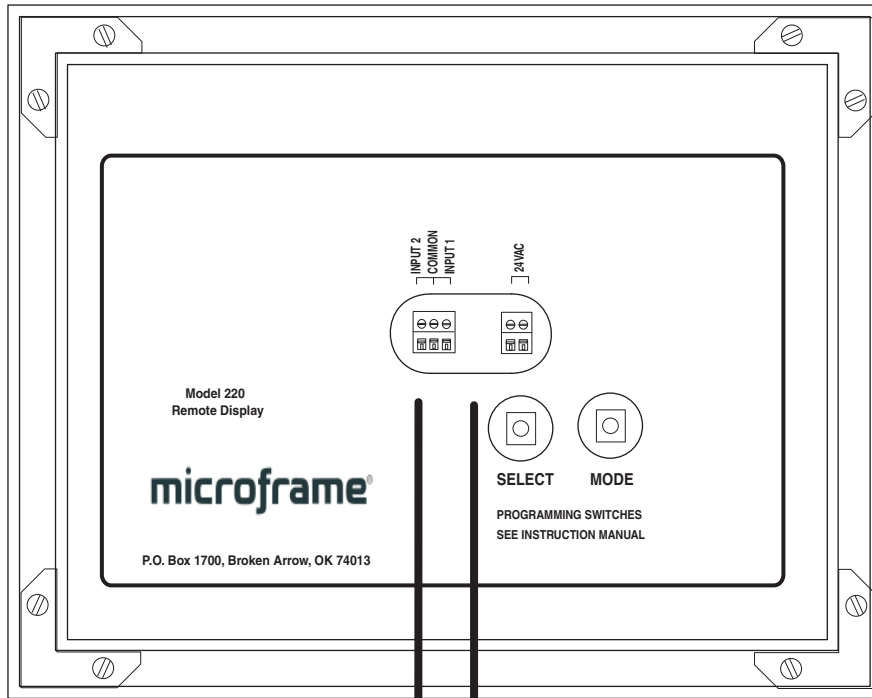

### RS-232C CONNECTIONS FOR 9-PIN D-Sub

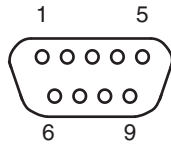

Pin 2 - T X ( Transmit Data ) ←

Pin 3 - RX ( Receive Data ) ←

Pin 5 - GND ( Signal Ground ) ←

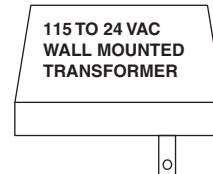

115 VAC @ .2 AMPS

2X01PX19706.AI

# RS/232 CONNECTION FOR : 230, 240, 260

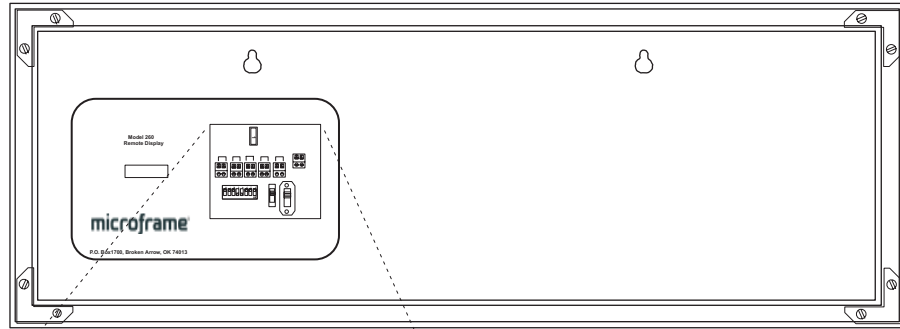

**A0260 DISPLAY**

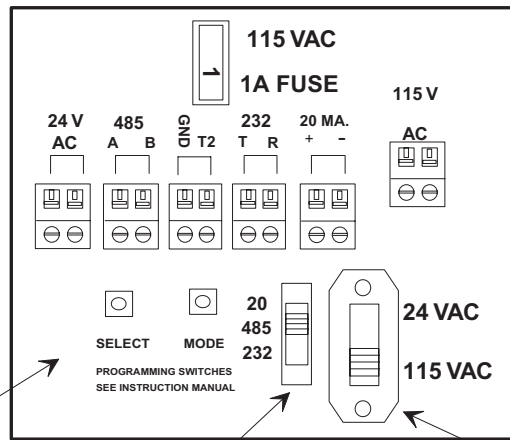

Communication and power connections.

Option Selection Switch

232, 485, 20ma Mode Switch

Input Power

Select Switch

RS-232C CONNECTIONS FOR 9-PIN D-Sub

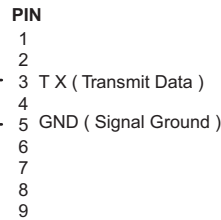

RS-232C CONNECTIONS FOR 25-PIN D-Sub

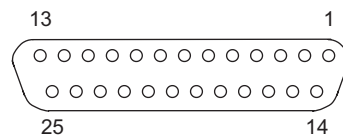
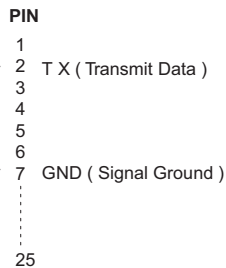

2X0\PX19705.ai



# RS232 & Power for A Model 265

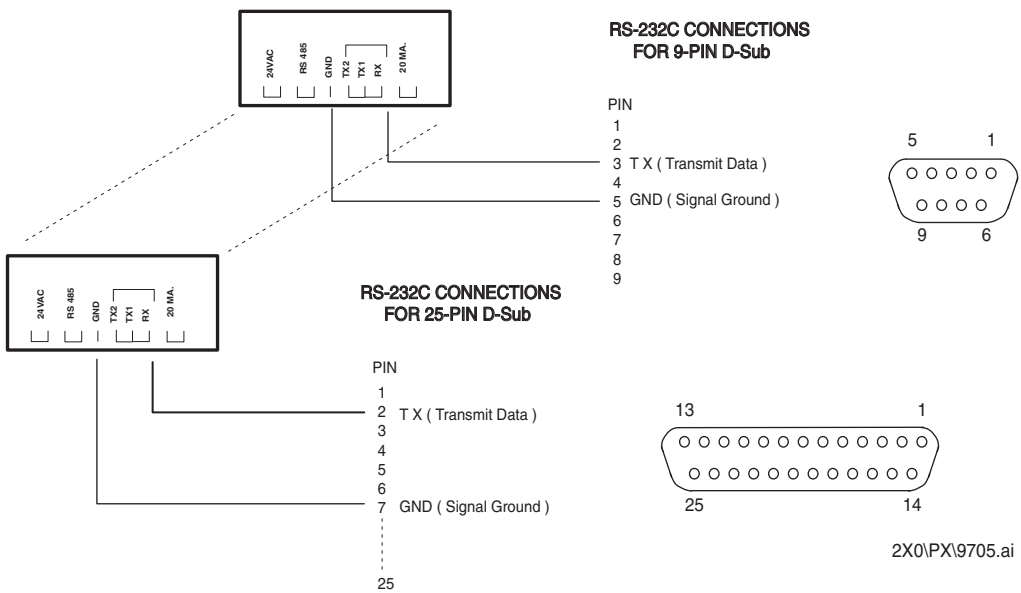
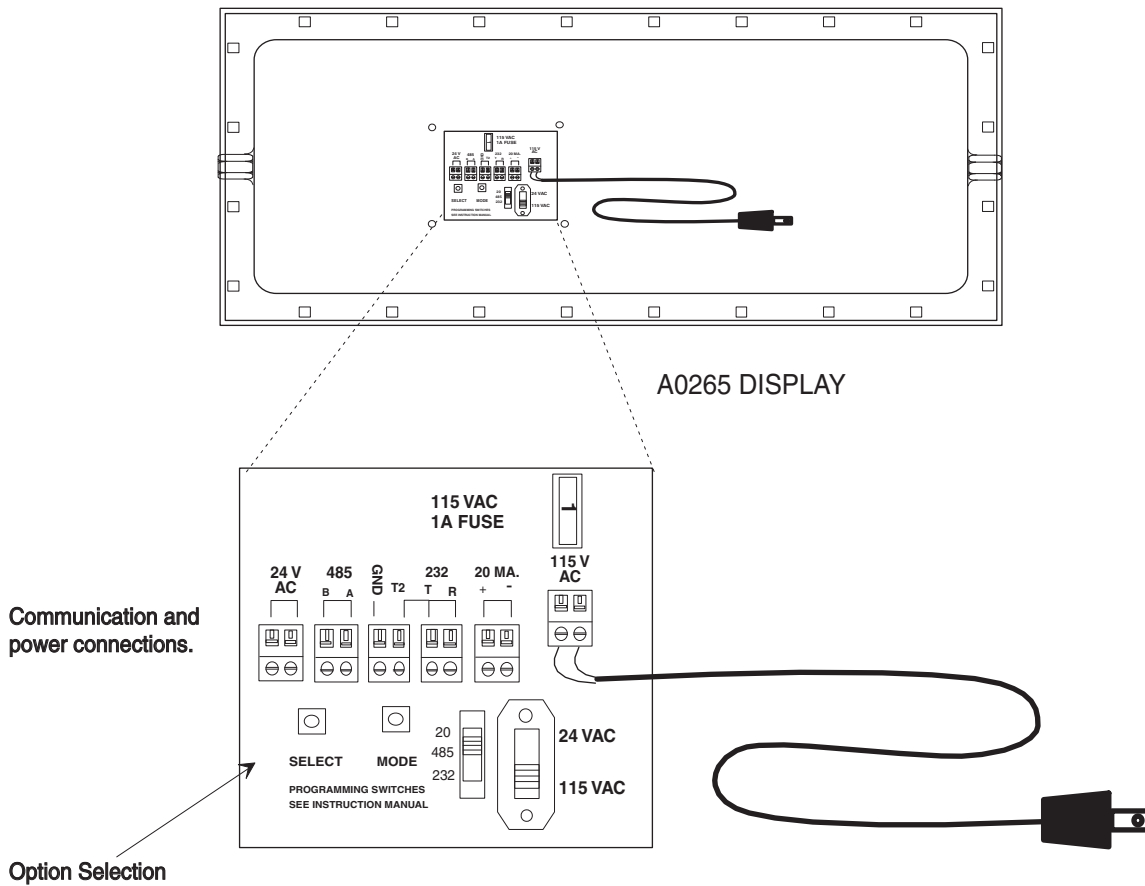

Be sure to set your computer ComPort to [Flow Control=None]. This will allow you to communicate with the Display without a null modem. Otherwise, your computer will be looking for a "Clear to Send" from the Display which is not connected.

# RS/485 Connection For Models 230, 240, 260, 265

Model A0265 6-Digit Display

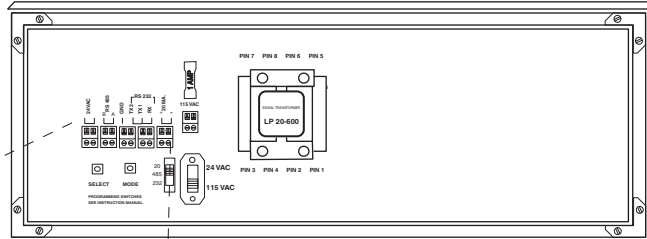
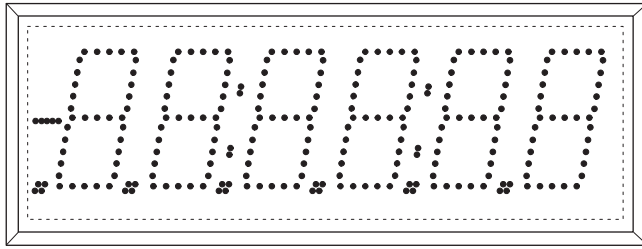

REAR VIEW

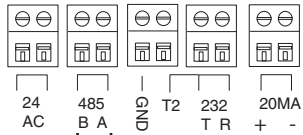

Model A0265 6-Digit Display

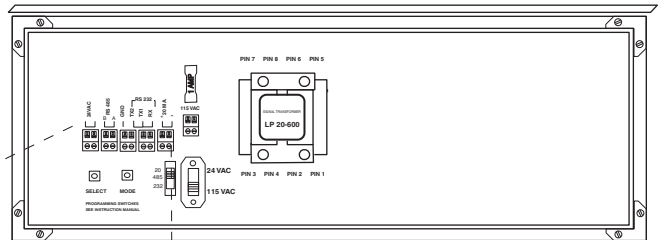
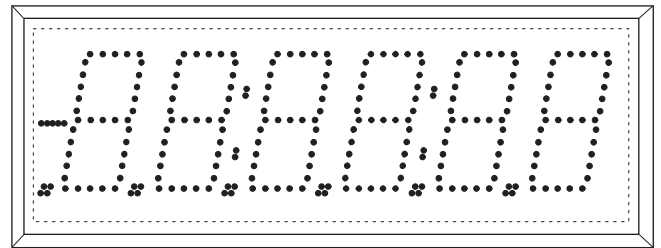

REAR VIEW

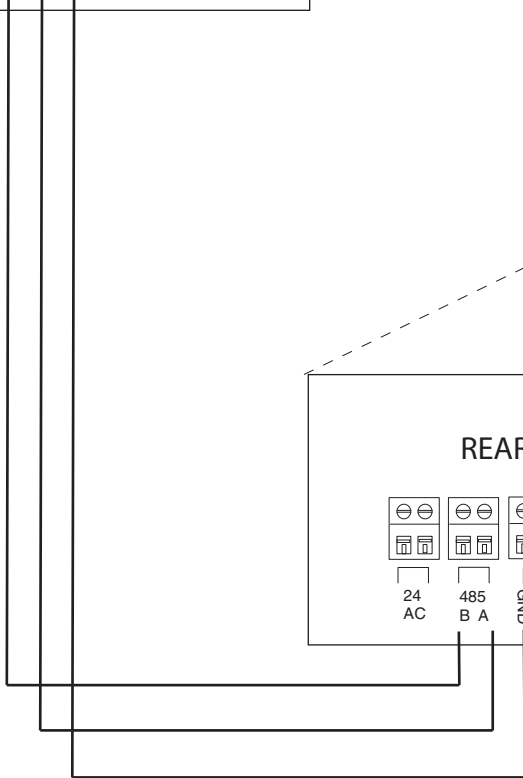
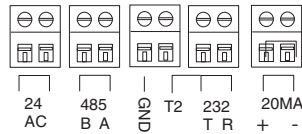

# Single Display 20 mA Current Loop Connections

Model A0265 6-Digit Display

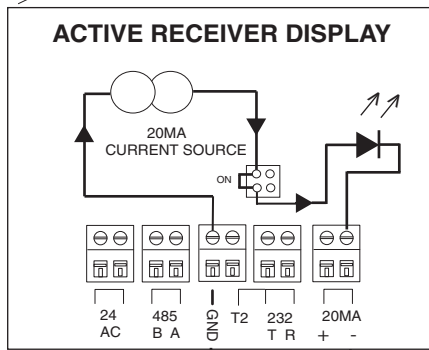
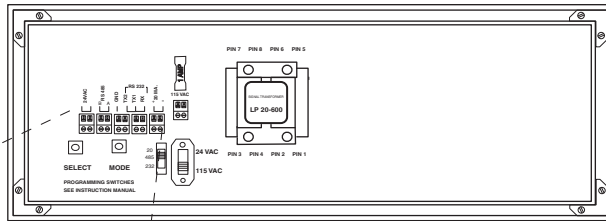
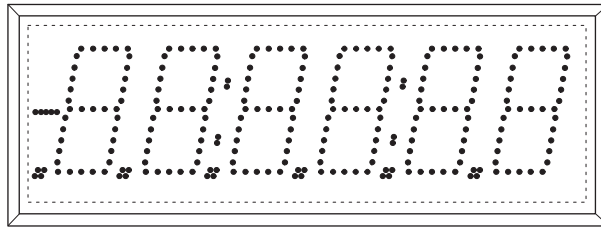

NON ISOLATED ACTIVE RECEIVER

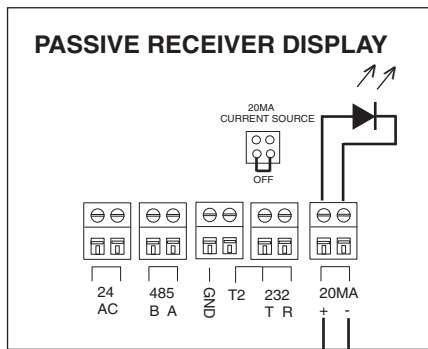

ISOLATED PASSIVE RECEIVER

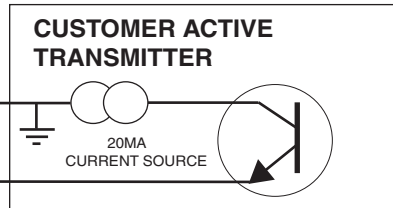

# Multiple Display 20 mA Current Loop Connections

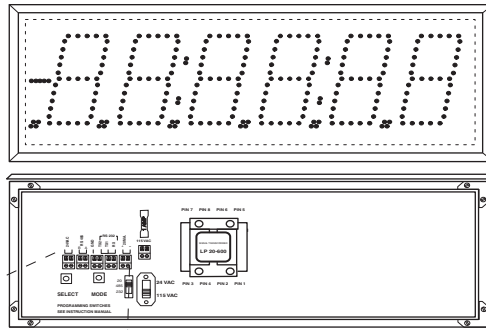

Model A0265 6-Digit Display

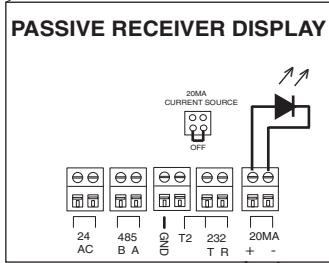

MULTIPLE DISPLAY PASSIVE TRANSMITTER

NOTE: Only 1 active receiver display per circuit

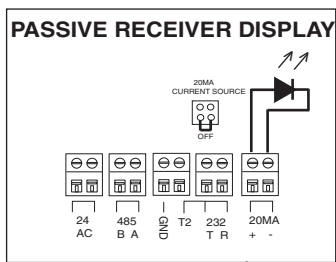
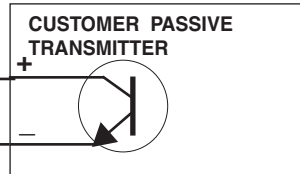
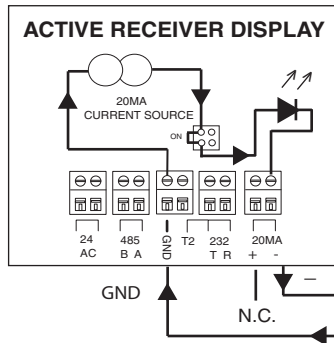

MULTIPLE DISPLAY ACTIVE TRANSMITTER

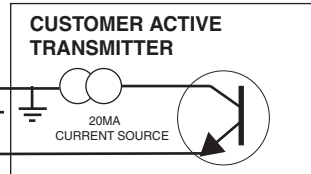
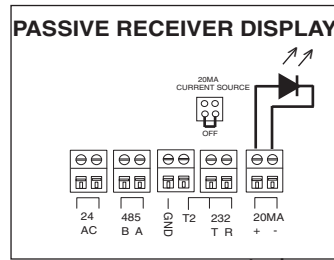

## TROUBLESHOOTING CHART

| SYMPTOM  | POSSIBLE CAUSE   | CURE   |
|--|--|--|
| No data on Remote Display and No <b>Processor LED</b> .  | No power to Remote Display.  | Check power source.  |
|  | Power not connected to proper input terminal or 24-110 volt or power switch not in proper position.  | If 24 VAC connected to 24V terminals then set power switch to 24 volt position. If 110 VAC connected to 110V terminals, then set power switch to 110 volt position.<br><br><b>CAUTION: Do Not CONNECT 110V to 24Volt terminal. Damage will occur to your Display.</b>  |
|  | Remote Display is dead.  | Remove back panel and measure voltage from fuse to ground. It should be 18-40 volts both sides. If fuse is blown, replace with 1 1/2 Amp 3AG fuse. If no voltage, then check supply voltage to Display. If voltage is present and fuse is okay, then set option 1 to test for all 8s. If this doesn't work, return to factory. |
| <b>Processor LED</b> blinks slow and never blinks fast and no data on Displays.                    | No data being received or receive circuit in Remote Display is dead.   | Processor blinking power light will change blink rate to fast blink each time data is received even if different baud rate. If blink rate remains unchanged then no data is being received. Check connections and transmitter.   |
|  | Data protocol switch not in proper position or data leads connected to wrong terminals.  | Set switch to match Display to data type. Set to 232 for RS232, 20 for 20 mA current loop and set to 485 for RS485. Connect proper signal to matching terminal.  |
| <b>Processor LED</b> blinks fast when transmitted to, but numbers don't display.                   | Wrong data being received or wrong baud rate. Processor blinks even if wrong baud rate so you know there is a connection.  | Verify correct Baud Rate. Check the data stream to see if it contains numbers and a carriage return.   |
| Remote Display shows 888 all the time.   | Self-Test Mode.  | Toggle the power or press the select button to get to count mode, then again to show the rev, and finally again to return to normal mode.  |
| First Remote Display works but second Remote Display does not work.                                | Check wiring between Displays. Check to see if Processor LED is blinking as above on second Display. Output from first Remote Display is dead or input to send Remote Display is dead. | Troubleshoot as above to determine if signal is arriving at the second Display. It could be the first Remote Display output or the second Remote Display input is not working. It may be necessary to swap the two Remote Displays to determine the problem. Return to factory for repair.                                     |
| The system works until connected to a second or third Display, then one or all units stop working. | The RS232 port is loaded by having more than one device connected to the single output of the computer at one time.  | Connect output of first Display to input of second Display. Connect output of second Display to input of third Display and so on. Do not connect all Displays directly to one computer because this will load the output of the computer.  |

**microframe<sup>®</sup>**

Microframe Corporation  
604 S. 12th Street  
Broken Arrow, OK 74012

Tel: (918) 258-4839  
Toll Free: 1-800-635-3811  
Website: [www.microframecorp.com](http://www.microframecorp.com)  
E-mail: [support@microframecorp.com](mailto:support@microframecorp.com)