

# microframe®

## SERIES 5100XXX8 INSTALLATION & SPECIFICATION GUIDE



---

**Microframe Corporation**  
604 South 12th Street  
Broken Arrow, OK 74012

Local: 918-258-4839  
Toll Free: 800-635-3811  
Website: [www.microframecorp.com](http://www.microframecorp.com)  
E-mail: [support@microframecorp.com](mailto:support@microframecorp.com)

---

**Revision Date: 11/2018**  
**Control: 1.1**

D5100XXX8-7010



### **Limited Warranty Agreement**

Your Microframe System is warranted against failure due to defects in workmanship or material for a period of one (1) year from the date of purchase. Microframe Corporation will repair or replace any defective unit. Obvious abuse or mishandling of the unit is NOT covered by this warranty.

### **Merchandise Return**

If your Unit does not work satisfactorily, please give us a call. We may be able to clear up the problem by phone. If it becomes necessary to return your Unit to the factory, please observe the following:

1. Call Microframe for an RMA number. This number authorizes you to return the product.
2. Place Unit in a sturdy box with sufficient packing material. Be sure the RMA number is on the outside of the box.
3. If requested, include the AC power adapter. It is not necessary to return the cable and connectors unless they are the problem.
4. Return the system insured and prepaid. Microframe is not responsible for shipping damages and losses on returned Units.

### **Warranty Service**

For warranty service, please contact Microframe toll-free at 800-635-3811. One of our technicians will be glad to assist you.

### **Assistance**

For any product assistance or maintenance help, contact Microframe by either calling 800-635-3811 or e-mailing us at: support@microframecorp.com.

### **Safety**

Do not install substitute parts or perform any modification to the product without first contacting Microframe.

### **Disclaimer**

We constantly strive to improve our products. Specifications are subject to change without notice.

### **Warning**

All power adapters, line cords, and electrical equipment should be kept out of the reach of children and away from water. (If you are installing cable in an air plenum area, such as a drop ceiling used for air return, you must use plenum-rated cable. The cable supplied from Microframe is rated CL2 and is approved for indoor installation everywhere except plenum areas.)

### **Life Support Policy**

Microframe's products are not authorized for use as components in life support devices or systems without the express written approval of the President of Microframe Corporation. As used herein:

1. Life support devices or systems are defined as systems which support or sustain life, and whose failure to perform when properly used in accordance with instructions for use provided in the labeling, can be reasonably expected to result in a significant injury to the user or any one depending on the system.
2. A critical component is any component of a life support device or system whose failure to perform can be reasonably expected to cause the failure of the life support device or system, or to affect its safety or effectiveness.

### **FCC Notice (for wireless products only)**

Note: This equipment has been tested and found to comply with the limits for a Class B digital device, pursuant to part 15 of the FCC Rules. These limits are designed to provide reasonable protection against harmful interference in a residential installation. This equipment generates, uses, and can radiate radio frequency energy and, if not installed and used in accordance with the instructions, may cause harmful interference to radio communications. However, there is no guarantee that interference will not occur in a particular installation. If this equipment does cause harmful interference to radio or television reception, which can be determined by turning the equipment off and on, the user is encouraged to try to correct the interference by one or more of the following measures:

- Reorient or relocate the receiving antenna.
- Increase the separation between the equipment and receiver.
- Connect the equipment into an outlet on a circuit different from that to which the receiver is connected.
- Consult the dealer or an experienced radio/TV technician for help.



# Series 5100 Installation and Specification Guide

## Table of Contents

Parts List _____	4
Getting Started _____	4
Using Your Remote or Push Buttons _____	5
Multiple-Display Systems _____	6
Multi-Window Service Systems _____	7
Multi-Window Service System Concept _____	8
Lobby Master Display Detailed Instructions _____	9
Lobby/Window Slave Display Detailed Instructions _____	10
Setting Programmable Options _____	11
Options Table Summary _____	11
Options Definitions _____	12
Appendix _____	13
Wiring Diagram _____	14
Multi-Window Service System Wiring Diagram _____	15
Multiple Adapter Connection Details _____	16
Optional External Chime Connection Detail _____	16
General Troubleshooting Chart _____	17
Model 5100XXX8 Specifications _____	18
Model 5100XXXW Specifications _____	19
Model 5100AXX8 Specifications _____	20
Model 5100AXXW Specifications _____	21

## **Parts List:**

1. Display
2. Remote Control with two AAA batteries (optional)
3. Two Brass Push Buttons with 40' of wire
4. Power Adapter with 20' of wire with spade lugs
5. Installation and Specification Guide
6. Screwdriver

## **Getting Started:**

### **Step 1: Screw-down Terminals**

All wire connections to Microframe displays are made with screw-down terminals located on the back of the display.

### **Step 2: Connecting Power**

Please refer to the diagram decal located on the back of the display.

- To connect power to the "24VAC" terminal on the display, first loosen the terminal's two screws. Then push one of the stripped ends of the power adapter wire into each opening in the side of the terminal. Tighten each screw onto each wire. Check that each wire is secure in each terminal by lightly pulling on it.
- To connect the power adapter wire to the wall mounted transformer, first loosen the screw-down terminals on the power adapter. Next, slide one spade connector under each terminal and tighten each screw onto the spade connectors.

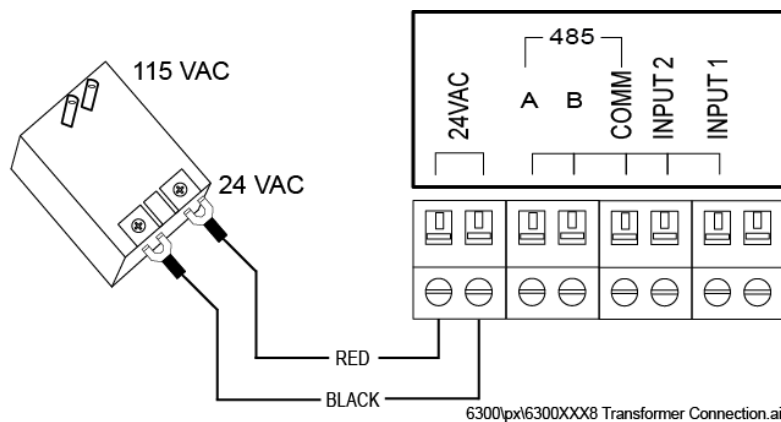

## **Getting Started continued...**

### **Step 3: Push Buttons (Optional)**

While this product can be fully controlled by the remote control, there are applications where it is desirable to use push button inputs.

**SAFETY NOTE: Only connect the push button wires to the screw-down terminals when the power to the display has been disconnected or unplugged from the power source.**

To connect the push buttons, cut to length two pieces of wire from the provided spool of push button wire, one for each button. Be sure the ends of the wire are properly stripped. Connect one end of each wire to a push button. At the other end of the wires, place the two remaining black conductors (one from each wire) under the "Common" terminal on the back of the display. Then put one of the red conductors from one of the wires under the "Input 1" terminal. Finally, put the remaining red conductor under the "Input 2" terminal. Be sure the screw-down terminal connections are secure.

### **Step 4: Hanging Display**

The display may be hung on a wall like a picture. For this purpose, you will find a "keyhole" mounting hole on the back of the display.

### **Step 5: Powering the Display**

Plug the power adapter into an AC outlet. The display's red LEDs should now be illuminated and show numeric characters.

**SAFETY NOTE: To avoid damaging your display, please disconnect the power before performing any service. Unplug the power adapter from the AC outlet to ensure there is no power going to the display.**

## **Using Your Remote or Push Buttons**

### **Using the Remote**

Please note that the Microframe Remote is specifically designed to work with your display.

CLEAR – resets the display to zero

UP / DOWN – counts up or down

ENTER – type a number followed by enter to change the count

EXIT – cancels an entry

MENU – puts the display into programming mode

### **Using the Push Buttons**

Press "Input 1" button to count up.

Press "Input 2" button to count down.

## **Multi-Display Systems**

General information on using several displays in one system.

### **Overview**

The 5100 Series allows multiple displays to work together as one system. The primary display is known as the "Master" display, while the displays controlled by the master are known as "Slave" displays. Slave displays get their information from the master via 485 Communication Protocol (Terminals A, B, COMM.)

### **Applications**

#### **Take-A-Number Systems (Standard)**

To have multiple displays all showing the same number in a Take-A-Number system, simply connect the displays as shown in the wiring diagrams. You may wire push buttons to any of the displays in the system. Pushing the buttons connected to any of the displays will cause the numbers to change on all of the displays. No programming is necessary for this option.

#### **Multi-Window Service System**

A Multi-Window Service System is a Take-A-Number system with the ability to have displays over multiple service counters. Each service counter display can show the number of the customer that is actually being served rather than the highest number. Because this is a complex configuration, there is an entire section of the manual dedicated to this topic. Please see "Multi-Window Service System" for further information.

#### **Wiring Considerations**

Connect slave displays to the master with 3- or 5- conductor wire. The communications bus requires three conductors. Communication runs can be up to 3,000 ft. long. Five conductor wire [22 AWG] provides two additional conductors used to carry power. As such, it is suitable for short power runs. For longer runs, use 3-conductor cable. On these longer runs, each display may be powered separately, or the displays may be broken up into groups powered by one adapter. For powering a group of displays, 18 gauge, 2-conductor wire is recommended for the power bus.

#### **Max Number of Displays Using a 0.9A Adapter**

		2-Digit	3-Digit
200 ft	22 awg	2	1
	18 awg	4	2
500 ft	22 awg	1	0

#### **Max Number of Displays Using a 1.2A Adapter**

		2-Digit	3-Digit
200 ft	22 awg	3	2
	18 awg	6	4
500 ft	18 awg	4	2

#### **Max Number of Displays Using a 2.5A Adapter**

		2-Digit	3-Digit
200 ft	22 awg	5	3
	18 awg	10	6
500 ft	18 awg	5	3



\*Regular brightness displays. For high brightness displays, divide the above quantities by 3.

# **Multi-Window Service System (MWSS)**

## **System Overview**

A Multi-Window Service System is an advanced Take-A-Number system. In a typical MWSS application, there are several clerks at a service counter. All of the clerks are serving a pool of customers, each who has a sequentially numbered ticket. The system can be best understood by studying the concept drawing on the next page.

There are three types of displays shown in the concept drawing. The 5100 Series displays can be set to any of these types using the programmable options.

### **Lobby Master**

The Lobby Master display shows the highest number being served. There can only be one Lobby Master per system.

### **Lobby Slave**

The Lobby Slave displays show the same number as the Lobby Master. You can have as many Lobby Slave displays as you need.

### **Window Slave**

Window Slave displays show the number currently being served by a particular clerk. You can have as many Window Slave displays as you need. Push buttons are attached to each Window Slave display.

## **System Operation**

Push buttons are generally connected to the Window Slave displays. When the clerk pushed the button connected to the display, the Lobby Master and Lobby Slave displays will increment by one. The Window Slave display whose button was pushed will show the same number as the Lobby Master. Other Window Slave displays will not change. In this way, customers in the waiting area will be able to see that the next number being served and can see which window to go to for service.

## **Setting Up the System**

To set up a MWSS, first wire the system as shown in the wiring diagrams. Next, program the display to the appropriate value in Area 1. Setting Area 1 to a 4 will cause the display to be a Lobby Master; setting Area 1 to a 5 will cause the display to be a Lobby Slave, and setting Area 1 to a 6 will cause the display to be a Window Slave. See the Setting Programmable Options section for details on how to change these values.

All displays may be hung on the wall like a picture frame.

## **Special Case MWSS**

In some cases, it may be necessary to have two Window Slave displays showing the same number. For instance, each service window has one display facing the customer, and another display facing the clerk so that the clerk can see the number they are about to serve. In this case, all of the Window Slave displays must be set to MWSS Slave Manual Address. This is done by setting Area 1 to a value of 7. In addition, each Window Slave display must be assigned an "address." This is done by setting the values of Areas 8 and 9. Window Slave displays with the same address will show the same number.

For details on setting the Values of these Areas, see the Setting the Programmable Options section.

# Multi-Window Service System Concept

Multi-Window Tag System Conceptual Drawing

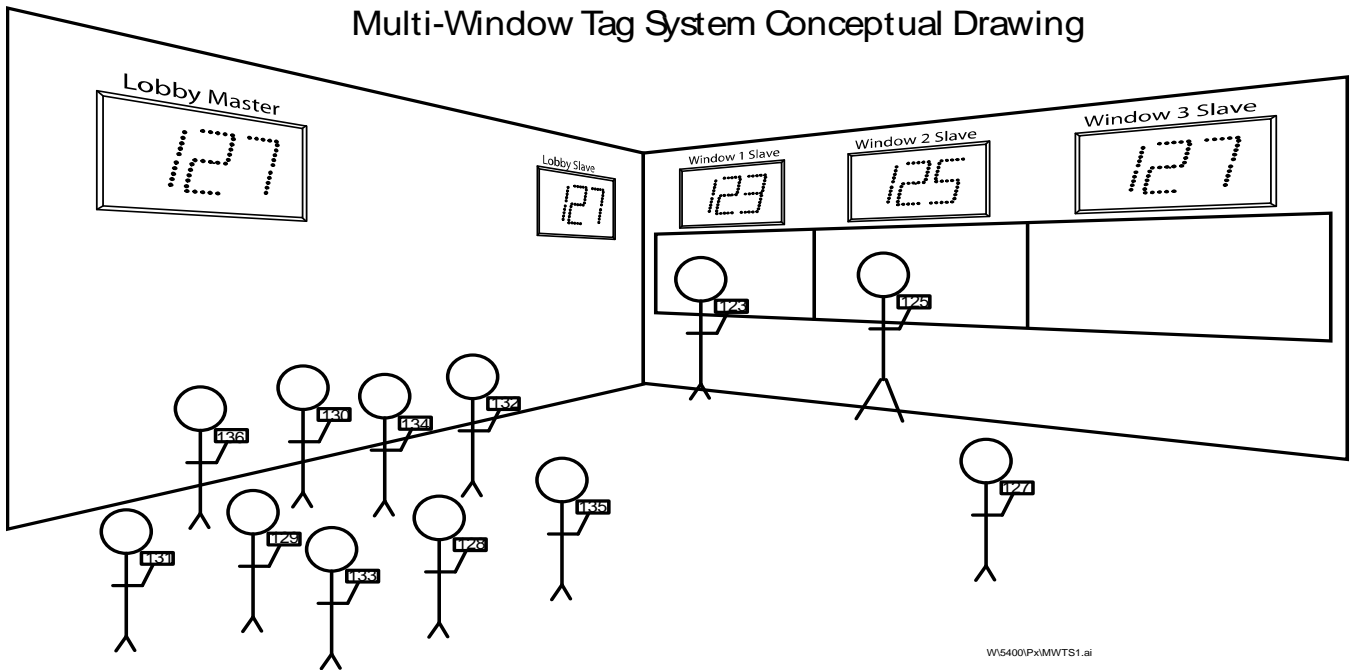



## **Lobby Master Display Detailed Instructions**

Shows the most current number being served.

### **Set the Display to Lobby Master Mode**

#### **Using Push Buttons**

Press [MODE] then press [ADVANCE] until you see "14". Press and hold the [MODE] button for 3 seconds to save the change. The display is now in Master mode.

#### **Using Remote Control**

Press [MENU] "4" [ENTER]. The display is now in Master mode.

### **Operation**

#### **Count Up**

Push the button wired as the Count Up button or push the Up button on your remote control.

#### **Count Down**

Push the button wired as the Count Down button or push the Down button on your remote control.

#### **Setting a New Number**

If you have push buttons, push and hold the "Count Up" button until the 10s digit begins to blink. You may now use the "Count Up" button to change the 10s digit, or continue holding the button down until the next digit on your display begins to blink. If you have a remote control, enter the desired number on the remote and then press the "Enter" button to accept that number. You can use this method to set all of the digits on your display.

#### **Reset to Zero**

If you have both the "Count Up" and "Countdown" push buttons connected, then pushing them both at the same time will cause the display to reset to all zeros. If you are using the remote control, press the "Clear" button to reset the displays to zero.

#### **Chime**

This display is equipped with an internal chime. By default the chime is off. When activated, the chime will sound with every number change.

- Push Buttons  
Press [MODE] until you see "50". Press [ADVANCE] for "51" or "52". Press and hold the [MODE] button for 3 seconds to save the change.
- Remote Control  
Press [MENU] then [UP] until you see "50". Type "1" or "2". Press [ENTER] to save the change.

### **Slave Displays**

The Master coordinates numbers for both Lobby and MWSS slave display. To form a system, each display must connect to a common 3-wire communications bus. For wiring details see the Appendix.

## **Lobby Slave Display Detailed Instructions**

The Lobby Slave display shows the same number as the Lobby Master.

### **Set the Display to the Lobby Slave Mode**

#### **Using Push Buttons**

Press [MODE] then press [ADVANCE] until you see "15". Press and hold the [MODE] button for 3 seconds to save the change. The display is now in Lobby Slave mode.

#### **Using Remote Control**

Press [MENU] "5" [ENTER]. The display is now in Lobby Slave mode.

#### **Automatic Arbitration**

Out of the box, these displays will automatically negotiate one Master with the remaining displays assuming Lobby Slave status. This means you do not need to set displays to Lobby Slave mode unless you wish to guarantee the position of the Master display. When displays change their status they will indicate the changes as "P4" (Master) or "P5" (Lobby Slave).

#### **Operation**

Operation of the Lobby Slave is identical to that of the Lobby Master display, including the use of push buttons and the remote control. To operate as a Lobby Slave, this display must be connected to the Lobby Master display.

## **Window Slave Display Detailed Instructions**

The Window Slave shows the current number at a clerk's window.

### **Set the Display to the Window Slave Mode**

#### **Using Push Buttons**

Press [MODE] then press [ADVANCE] until you see "16". Press and hold the [MODE] button for 3 seconds to save the change. The display is now in Window Slave mode.

#### **Using Remote Control**

Press [MENU] "6" [ENTER]. The display is now in Window Slave mode.

### **Set the Display to MWSS Slave Manual Address**

#### **Using Push Buttons**

Press [MODE] then press [ADVANCE] until you see "17". Press and hold the [MODE] button for 3 seconds to save the change. The display is now in MWSS Slave mode.

#### **Using Remote Control**

Press [MENU] "7" [ENTER]. The display is now in MWSS Slave mode.

#### **Operation**

To avoid having all displays respond to the remote control, MWSS Slaves ignore Count Up / Count Down commands from the remote.

#### **Count Up**

Push the button wired as the "Count Up" button. The Lobby Master will count up by one and this display will show the new number.

#### **Count Down**

Push the button wired as the "Count Down" button. This is useful if the clerk accidentally advances the count. This 'undo' feature is not available after another MWSS display takes a number.

#### **Display Blanking**

When a clerk goes on break, they may blank their display by holding the "Count Down" button for 3 seconds. The display will no longer be blank when any button is pressed.

# Setting the Programmable Options

## Overview

Programmable Options are separated into ten Areas. Each Area has an assigned value. When in programming mode, the Area is denoted on the display by the “10s” digit, and the Value is denoted on the display by the “1s” digit.

## Setting Options

### Using the Programming Buttons

These buttons are the three buttons on the back of the display, designed to program your system and they are labeled, “Mode”, “Select”, and “Advance”.

To enter a programming mode, press the [MODE] button once. You will see the first Area along with its Value. Tap the [MODE] button until the desired Area is reached. To set the Value on an Area, tap the [ADVANCE] button until you see the desired Value. To save changes, press and hold the [MODE] button for three second. To discard changes, do nothing and the display will revert to the last settings.

### Using the Remote Control

The remote control is an optional piece of equipment, and is very useful in setting up and operating your display.

To enter a programming mode, press the [MENU] button. Press the [UP] and [DOWN] buttons to navigate between Areas. To set a new Value, simply type that number on the remote. To save changes, press [ENTER]. To discard changes, press [EXIT].

## Options Table Summary

Options in **bold** are the Default settings from Microframe.

0	Keyfob Address <b>0.0 Address 0</b> 0.1 to 0.9 Addresses 1-9	5	Internal Chime <b>5.0 Off</b> 5.1 Single 5.2 Double	8	Address Tens ** 8.0 Address 00 8.1 to 8.9 Address 10-90
1	Operation <b>1.4 Master</b> 1.5 Lobby Slave 1.6 MWSS Window Slave 1.7 MWSS Slave Manual Address	6	Chime Volume 6.0-6.4 Low 6.5-6.9 High	9	Address Ones ** 9.0 Address 0 9.1 to 9.9 Address 1-9
2	Display Size 2.2 2-Digit 2.3 3-Digit	7	External Chime * 7.0 Off 7.1 0.1s 7.2 0.2s	A	Display Brightness 1-100%
3	Zero Suppression 3.0 Off <b>3.1 Suppress Leading Zeroes</b>		7.3 <b>0.3s</b> 7.4 0.5s 7.5 1.0s		
4	IR Lockout 4.0 Ignore Remote <b>4.1 Enable Remote</b>		7.6 3.0s 7.7 5.0s 7.8 10.0s 7.9 20.0s		

\* = Must specify Relay or Triac option when ordering

\*\* = Used with Option 1.7, otherwise auto-set

## **Options Definitions**

Helpful information about all of the choices shown in the Options Table Summary.

### **0 Keyfob Address**

This option is for our wireless displays. This adds the ability to set a keyfob address. This allows for independent keyfob/display systems to be used side-by-side. Note: pressing two keyfobs at the same time will still cause interference, because all keyfobs operate on the same frequency.

### **1 Operation**

This Area determines the operation of the display.

**1.4 Master** - The standard Take-A-Number mode

**1.5 Lobby Slave** - Will display the same number as the Master

**1.6 MWSS (Window) Slave** - Used over counter / service windows

**1.7 MWSS (Window) Slave Manual Address** - Allows a secondary display to be set up inside a counter / service window to echo the display outside the window

### **2 Display size**

The display looks at this Area to see how many digits it has. It is set at the factory to match the number of digits of the display, i.e., a 3-digit display would have a "3" in this Area.

### **3 Leading Zero Suppression**

The value in this area determines whether or not your display will show leading zeros, i.e., the difference between seeing "000001" on your display and seeing "1".

**3.0 Show leading zeroes**

**3.1 Hide leading zeroes**

### **4 IR Lockout**

This Area controls whether the display ignores or responds to the remote control. This helps prevent accidental changes to displays in a multi-display installation. To toggle IR Lockout using the remote, hold the [EXIT] button for 5 seconds. The display will indicate the change by showing "ir0" or "ir1."

**4.0 Lockout Remote**

**4.1 Allow Remote**

### **5 Internal Chime**

This Area controls how many times the internal chime will sound.

**5.0 – Off** - no chime

**5.1 – Single** - chime once

**5.2 – Double** - two chimes

### **6 Chime Volume**

The internal chime can be set to half or full volume. 0-4 Low, 5-9 High.

### **7 External Chime**

This area controls the duration of the external chime driver circuit. The external driver can be activated from 0 to 20 seconds.

Note: The external chime option must be specified at the time of order. Dry contact (relay) and AC load (Triac) drivers are available. The maximum input voltage is 24V AC/DC. Typical uses include a triac driving a doorbell chime, and a relay sending a control signal to another device.

### **8 Display Address "Tens" Digit**

This is used in the Multi-Window Service System configuration to set the address of Window Slaves; it stores a value from 0-9. See the Multi-Window Service System for further details.

### **9 Display Address "Ones" Digit**

This is used in the Multi-Window Service System configuration to set the address of Window Slaves; it stores a value from 0-9. See the Multi-Window Service System for further details.

**A Display Brightness** – Used to match the perceived brightness between colored displays, e.g. green vs blue.



# microframe®

**SERIES 5100XXX8**

## **APPENDIX**

# Wiring Diagram

The diagram below shows a multiple display system running off of one power adapter (transformer). Although the drawings only show buttons connected to one display, you may connect buttons to each display in the system, depending on your application.

**Note: While each display may have its own buttons, an individual button should not be connected to multiple displays.**

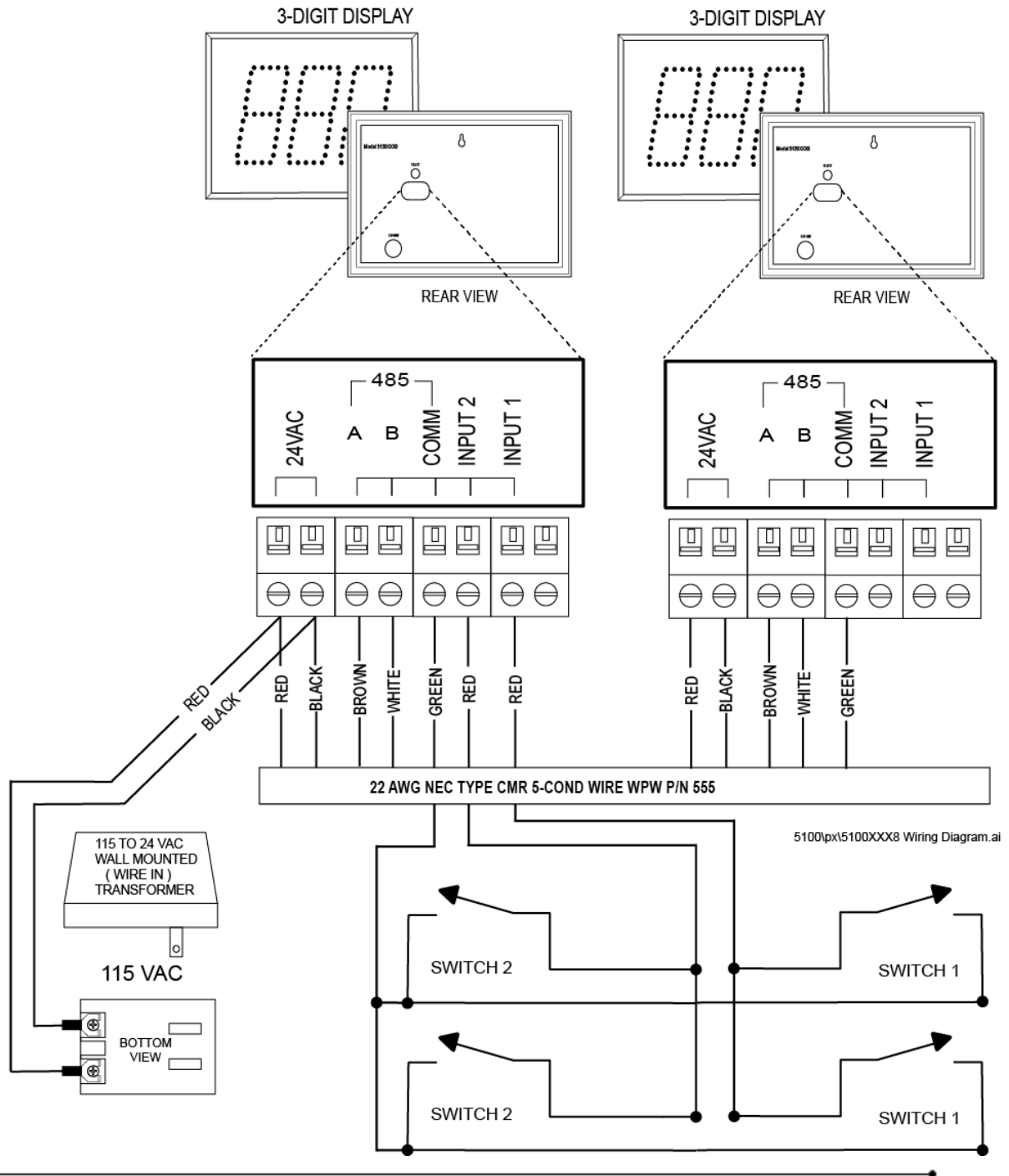

# Multi-Window Service System Wiring Diagram

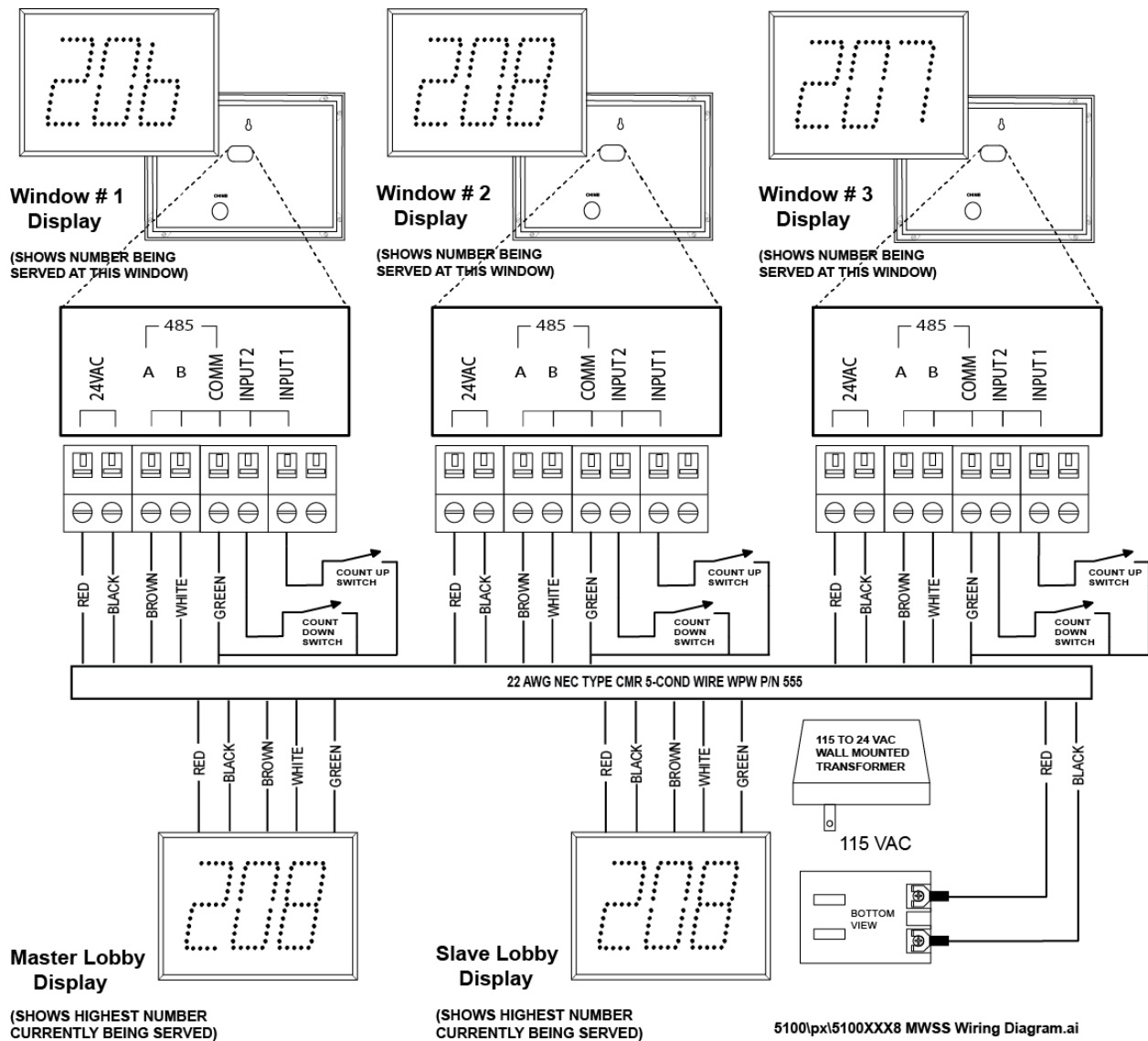

## Multiple AC Adapter Connection Detail

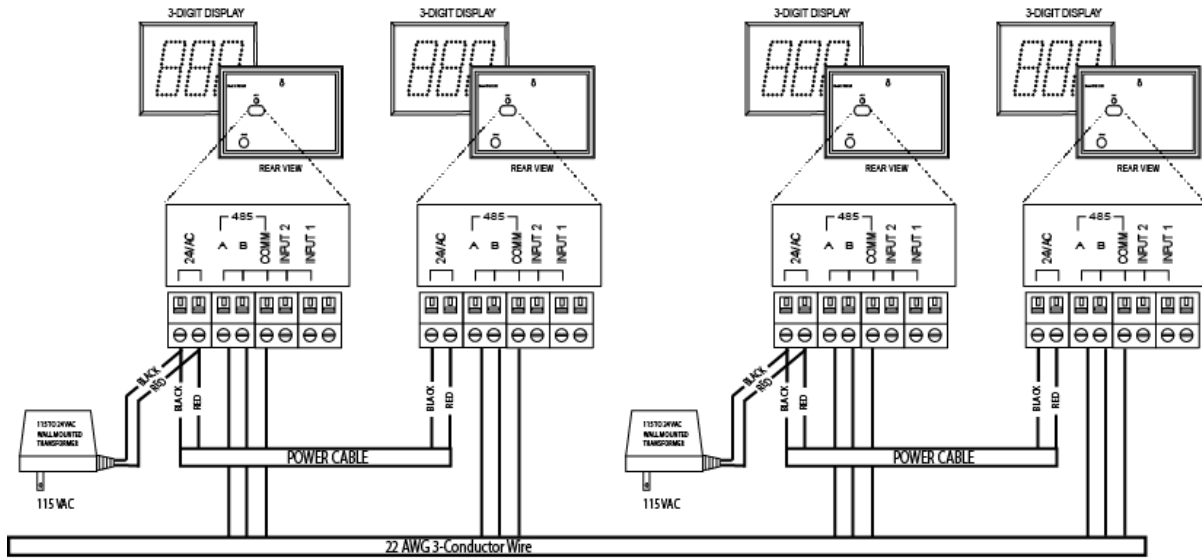

5100\px\5100XXX8 Wiring Diagram MultiAC.ai

## Optional External Chime Connection Detail

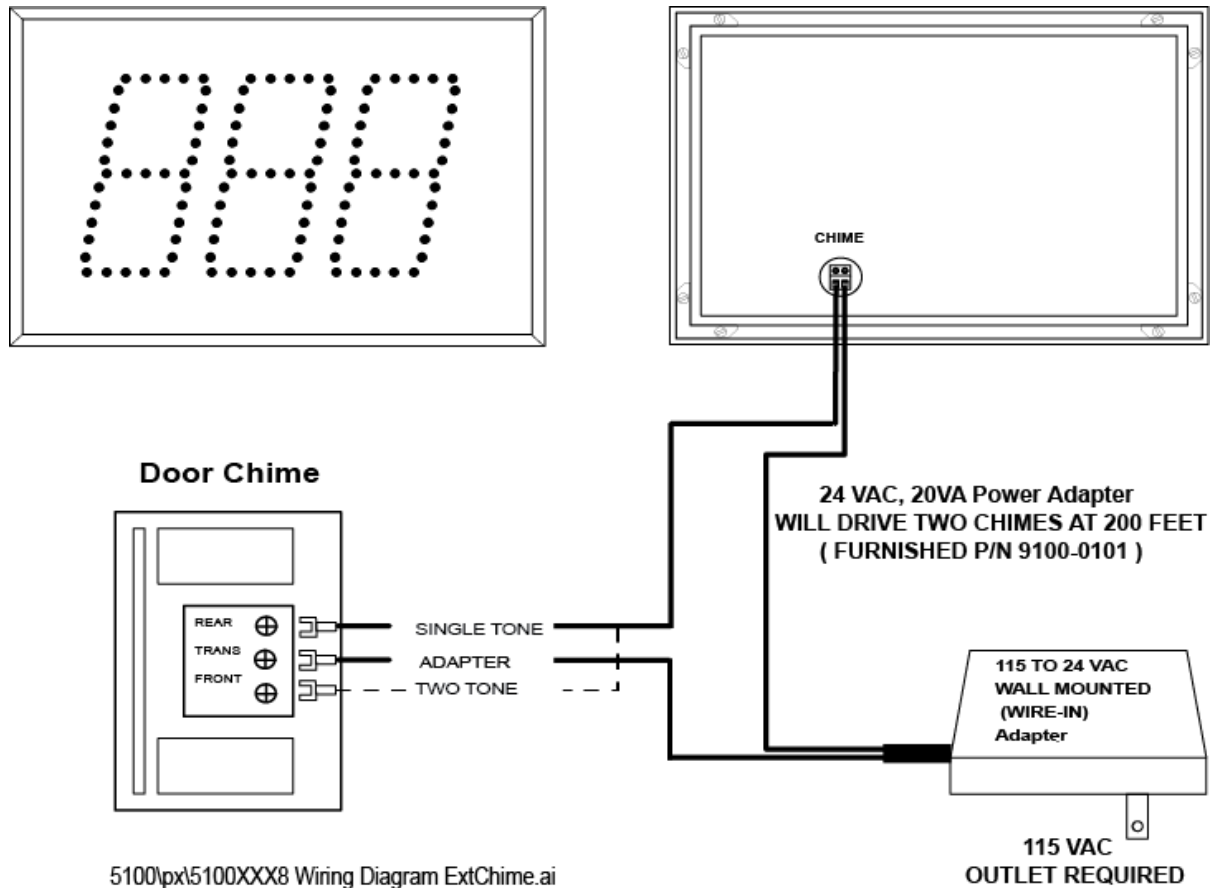

5100\px\5100XXX8 Wiring Diagram ExtChime.ai



## General Troubleshooting Chart

SYMPTOM	POSSIBLE CAUSE	CURE
Display will not light up.	Display is not plugged in or power adapter is bad.	Check AC wall connection or change to another wall outlet.
Display lights up but will not respond to wired buttons.	Poor or no signal connection to buttons.	Check signal cable connections to buttons and check for proper wiring on back panel. Try with a short cable to prove whether the problem is in the units or in the cable.
One or more segments do not light up.	One or more LEDs burned out. Typically caused only when lightning-strikes.	Call Microframe to receive an RMA and then return to factory for repair.
Different displays are showing different numbers or times.	Poor signal connection to master display or displays are in different modes.	Check signal cables and routing. Make sure 'A' and 'B' wires are not reversed. Check Programmable Options to make sure correct modes are selected.
MWSS slave [option 1.6 or 1.7] is alternating between number and dashes.	Loss of communication to master display	Check that master is operating properly. Check wiring between master and window slaves.
<b>Remote Control Troubleshooting</b>		
Remote control buttons stopped responding.	Remote Locked Up  Batteries dead	Remove Batteries. Press [Clear] 5 times. Insert batteries and check for operation. Replace batteries.

## Model 5100AXX8 Specifications

### Features

The 5100AXX8 series is an 8" high brightness version of our Take-A-Number display.

Box contents:

- (1) Display
- (1) Screwdriver
- (1) 24VAC adapter w/ 20ft Wire
- (2) Brass Push Buttons
- (1) Bundle 40ft wire for buttons

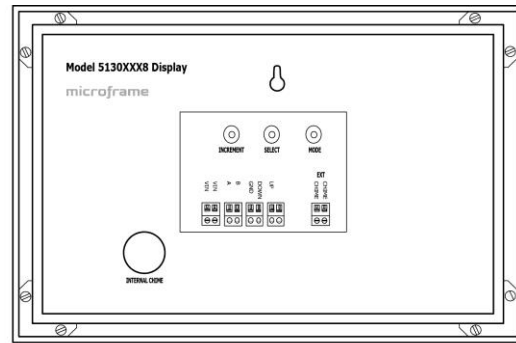
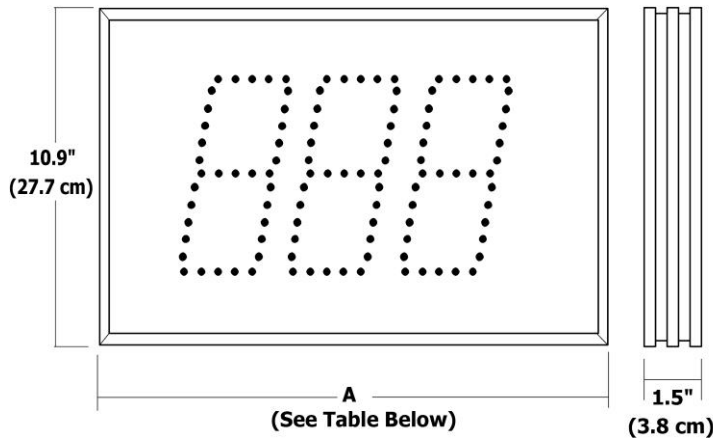

5100\px\5100XXX8 Dimensions.ai

### Model 5100AXX8 Specifications

Voltage Input Requirements.....	12 VDC or 18-24 VAC	
Character Height.....	8 inches	
Character Viewing Distance.....	250 feet	
Temperature Parameters.....	-20°C to 60°C (-4°F to 140°F)	
Casing.....	Aluminum extrusion	
Color.....	Black frame with dark red acrylic faceplate	
Environment.....	Indoor use or weather resistant case option	
Display Size	<b>2-Digit</b>	<b>3-Digit</b>
Power Requirements (Watts) @ 100% bright	17.2 W	23.3 W
Current @ 12VDC	1.43A	1.94A
Current @ 24VAC	0.72A	0.97A
Weight	3.3 lbs	4.7 lbs
Width "A" Dimension Inches (Centimeters)	11.5 (29.2)	16.4 (41.7)